

# INSTALLATION INSTRUCTIONS

## FRANCE *Tru-Power*™ Model LED-1260MPS LED Power Supply

- READ AND FOLLOW ALL SAFETY INSTRUCTIONS.
- Read and follow all instructions that are on the product or provided with the product.
- Installation work and electrical wiring must be done by qualified person(s) in accordance with all applicable codes and standards, including fire-rated construction.
- **WARNING: Risk of Electric Shock. When used outdoors, install only on a circuit protected by a Class A GFCI.**
- **WARNING: Risk of Electric Shock. Protect from weather.**
- **WARNING: Risk of Fire. Installation involves special wiring methods to run wiring through a building structure. Consult a qualified electrician.**
- Turn power off at fuse or breaker panel before installation, inspection, service or removal.
- For use in Dry or Damp locations only.
- Power Supply must be properly grounded before operation.
- All wiring must be rated at 105°C or greater and installed per the National Electrical Code® (NEC) and applicable local codes.
- **SAVE THESE INSTRUCTIONS – This manual contains important safety and operating instructions for power units.**

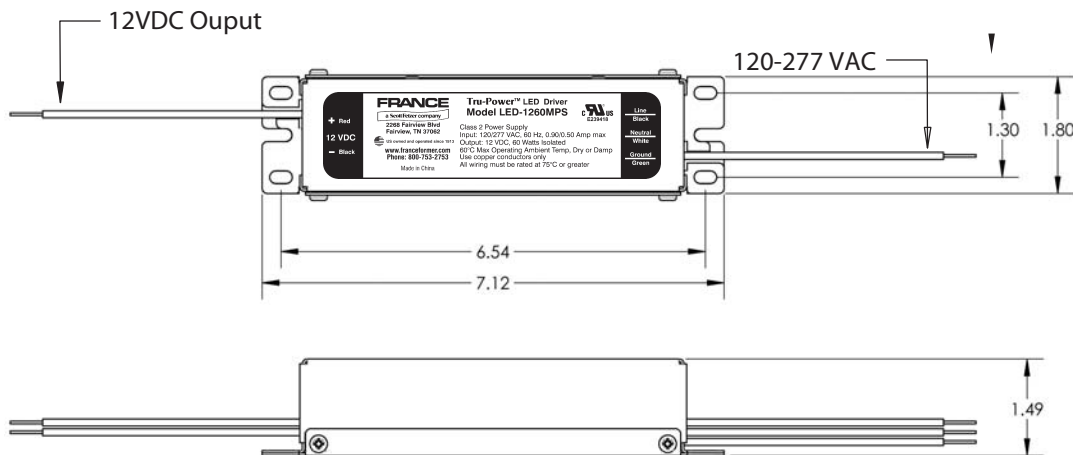

### Power Supply Features

- The LED-1260MPS is a Class 2, 12VDC, 60 watt power supply for operating France or other LED Modules.
- Dry and Damp location use only: must be mounted indoors or outdoors in letters, raceways, transformer LED cans, LED cans (if installed per these instructions).
- Allowable operating ambient temperature adjacent to the power supply is -40°C to +60°C with proper mounting and air flow. With proper air flow, no power derating is required for temperatures up to 60°C.
- Low profile, fully potted construction provides maximum durability.
- 8" long input and output leads.
- UL Recognized.
- Complies with FCC Part 15.

### Prevention of Overload

Use caution not to overload this power supply with LED's. Overloading can cause power supply over-temperature shutdown or premature failure. To assure overloading does not occur, assure the total power of the LED string does not exceed 60 watts at maximum operating ambient temperature.

# INSTALLATION INSTRUCTIONS

## FRANCE *Tru-Power*™ Model LED-1260MPS LED Power Supply

### Step 1 Before you begin

Assure all power to the sign or mounting enclosure is turned off. Read these installation instructions thoroughly before beginning installation work. Electrical wiring of these power supplies shall be performed only by qualified service personnel in accordance with all applicable codes and standards, including fire-rated construction. During installation, please refer to Fig. 1, page 1.

### Step 2 Mounting and primary circuit wiring

**The power supply ground wire (green) and any enclosure containing the power supply must be connected to branch circuit safety ground! Make sure to use the correct wire type for the application.**

In the end product, power supply spacing to other heat producing components shall be 1 inch (25.4 mm) or more apart when arranged end-to-end, and 4 inches (102 mm) or more apart when arranged otherwise.

**In open air - dry location:** Not allowed - must be installed in an electrical enclosure.

**Inside outdoor channel letter, raceway, or sign cabinet qualifying as an electrical enclosure per UL48 or in a remotely mounted electrical enclosure:** Securely mount power supply via integrated mounting holes using a minimum of two No. 8 screws or bolts/nuts. Splice the line and neutral wires to the power supply input leads as indicated on the product label. Bond both branch circuit ground and power supply ground to the electrical enclosure. Any enclosure must have an internal volume not less than three times that of the power supply's volume (3 times volume = 30 cu. in.), and shall provide adequate ventilation to assure the maximum ambient air temperature near the power supply never exceeds 60°C (140°F). If adequate volume or ventilation is not supplied, the warranty is voided.

**Inside outdoor channel letter, raceway, or sign cabinet not qualifying as an electrical enclosure per UL48:** The power supply must be mounted in an electrical enclosure with internal volume not less than three times that of the power supply volume (3 times volume = 30 cu. in.) and which provides adequate ventilation to assure the maximum ambient air temperature near the power supply never exceeds 60°C (140°F). (If adequate volume or ventilation is not supplied, the warranty is voided). Mount the power supply in the electrical enclosure via integrated mounting holes using a minimum of two No. 8 screws or bolts/nuts. Securely mount power supply/electrical enclosure. Using wet-listed hardware, attach primary circuit conduit to the electrical enclosure. Route branch circuit wiring through the conduit into the electrical enclosure. Splice the line and neutral wires to the power supply input leads as indicated on the product label. *Bond both branch circuit ground and power supply ground to the electrical enclosure.* Attach cover to electrical enclosure.

**Exposed to weather - wet location:** Not allowed - must be mounted in weatherproof enclosure. Follow instructions in last paragraph.

### Step 3 Secondary Circuit Wiring

Route the 12 VDC wiring from the LED load to the power supply per the requirements of NEC, UL48 and any local codes. Wiring between LED modules and the power supply must be at least AWG 18 and kept as short as possible. If such wiring is exposed to rain or sunlight, PLTC cable must be used if wiring is exposed to weather. Connect +12VDC LED wires to the power supply RED output wire. Connect the -12 VDC LED wires to the power supply BLACK output wire as indicated on the product label. Splices to the power supply output wires must be located within the required electrical enclosure mentioned earlier. Use an NEC compliant splicing method. Use caution not to damage the wire insulation.

### Step 4 Energize Circuit

Energize the primary circuit. If the LED's do not light, check primary power and/or refer to "Troubleshooting" below. To check if the power supply is overloaded, measure power supply input current: at 120VAC input the input current should be less than 0.95A; at 277VAC input voltage the input current should be less than 0.52A. If these limits are exceeded, reduce the number of LED's connected to the power supply.

### Troubleshooting

If after applying power to the power supply the LED modules do not light, a short or open likely exists in the LED string. Remove primary power and check all electrical connections for short circuit, pinched wires or bad splices. Verify the LED modules' positive (+) and negative (-) leads are connected to the power supply's red and black leads respectively. Repair any defective connections. Re-energize the power supply. If the modules still fail to light, remove primary power, disconnect LED load, connect a DC voltmeter to the RED to BLACK output leads, and reapply primary power. If the meter reads less than 11.8 volts, call Customer Service at France: 800-793-4793.

**Note: A disconnect switch of the appropriate rating must be incorporated in the field within 29.5' (9 meters) of the LED power supply. The switch must be rated for the branch circuit voltage and twice the total actual or rated input current of the power supply or supplies.**

## WARRANTY POLICY

France, a Scott Fetzer Company, warrants to the original purchaser the following products to be free from defects in material and workmanship at the date of shipment. This warranty is conditional based upon proper installation, use and maintenance of the product. This warranty is not applicable to any product not installed and operated in accordance with France specifications and connection diagrams or which have been subjected to abnormal operating conditions.

NO OTHER WARRANTY, WHETHER EXPRESS OR IMPLIED, INCLUDING ANY WARRANTY OF MERCHANTABILITY OR FITNESS FOR A PARTICULAR PURPOSE, SHALL EXIST IN CONNECTION WITH THE SALE OR USE OF SUCH PRODUCTS. All claims under this warranty must be made in writing and delivered to the Company prior the expiration of the established warranty period from the date of manufacture.

Upon receipt of the claim, the Company shall inspect the part(s) claimed to be defective, and shall repair, or at its option, replace, free of charge, any part(s) determined to have been defective at the time of shipment from the factory. If circumstances are such as to preclude the remedying of warranty defects by repair or replacement, the Company shall, upon the return of the products, refund to buyer any part of the purchase price paid to the Company for the stated products. Inspection shall be performed at the Company's plant or at such other place as may be designated by the Company; and, freight for returning products for inspection shall be paid by the buyer.

The foregoing states the sole and exclusive remedy for any breach of warranty or for any other claim based on any defect in, or non-performance of, the products, whether sounding in contract, warranty or negligence. WITHOUT LIMITING THE GENERALITY OF THE FOREGOING, THE COMPANY SHALL UNDER NO CIRCUMSTANCES BE LIABLE FOR ANY INCIDENTAL OR CONSEQUENTIAL LOSS OR DAMAGE WHATSOEVER ARISING OUT OF, OR IN ANY WAY RELATING TO, ANY SUCH BREACH OF WARRANTY OR CLAIMED DEFECT IN, OR NON-PERFORMANCE OF, THE PRODUCTS.



2268 Fairview Blvd., Fairview, TN 37062  
(800) 793-4793 [www.franceformer.com](http://www.franceformer.com)