

# WESTRIM™

## PRODUCTS

A FRANCE COMPANY

# HI-VOLT

## High Voltage Junction Box

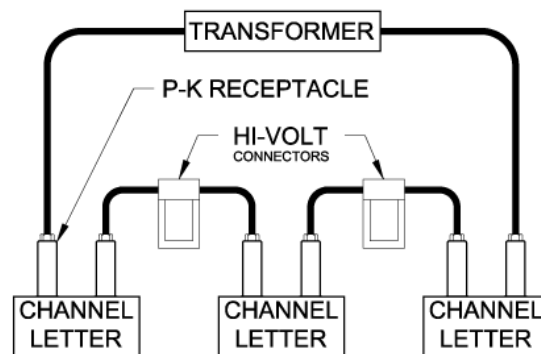

TYPICAL SIGN LETTER INSTALLATION

- ◆ Splices two GTO cables
- ◆ Simplifies installation, improves quality, reduces installation costs!
- ◆ Rated for 7500 volt applications, including 15000 V mid-point referenced transformer installations
- ◆ Electrical grade porcelain and zinc plated steel construction
- ◆ 1/2" conduit knock-outs (one on each side and two on the bottom)
- ◆ Channel letters are fully assembled in the shop with the electrode receptacles installed, tubes mounted, wired complete with flex conduit and GTO. At the installation site, the letters are mounted to the building and wired to one another using the Hi-Volt Connector. This procedure reduces glass breakage.

Description	Part #	Catalog #	Packaging	Weight
Hi-Volt Connector	38043	HI-VOLT	25 per box	44 lbs./box



[www.westrimproducts.com](http://www.westrimproducts.com)

# HI-VOLT

## High Voltage Junction Box

### PRODUCT USAGE:

This product is listed for the purpose of making connection between two GTO wires in dry locations. The GTO wires are to be routed to the **HI-VOLT** connector through listed conduits and fittings.

### ELECTRICAL RATINGS:

Secondary Voltage: 7500 VAC to ground or 15000 VAC midpoint referenced

### INSTRUCTIONS FOR USE:

- 1) Disassemble the **HI-VOLT** unit into (4) parts: metal box and lid, ceramic base and inner cup.
- 2) Attach the metal box to the mounting surface by bolting or screwing through the two mounting holes on the back.
- 3) Remove two knockouts in the box and connect the listed conduit. All knockouts shall be in place or filled with conduit.
- 4) Slide the ceramic base into the mounted metal box.
- 5) Feed the GTO into the **HI-VOLT** unit; Strip 1" from the ends of the two GTO leads and attach them to the terminal post in the ceramic base between the flat and cup washers.
- 5a) Use care not to over-tighten the nut, as it could break the stud loose, ruining the box.
- 6) Replace the ceramic inner cup into the ceramic base.
- 7) Secure the metal lid in place with the nut provided.

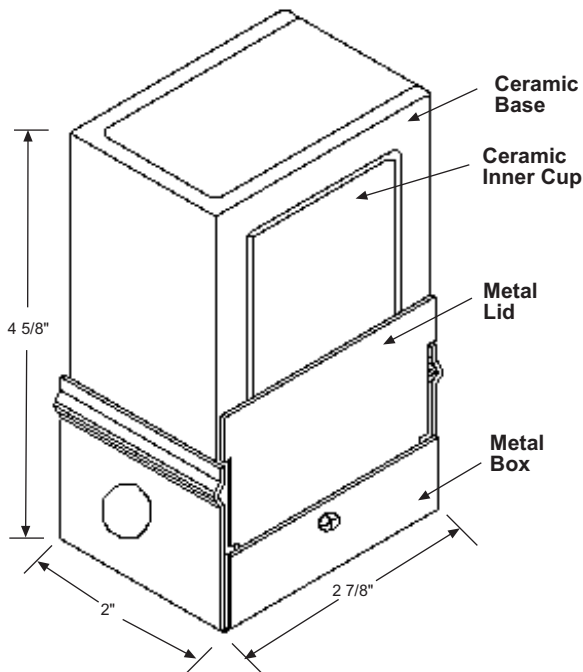

The **HI-VOLT** connector enables the sign manufacturer to make approved high voltage splices. This is particularly beneficial in the installation of channel letters. The channel letters are fully assembled in the shop with the electrode receptacles installed, tubes mounted, wired complete with flex conduit and GTO. At the installation site, the completed letters are mounted to the building and wired to one another using the **HI-VOLT** connector as shown below. This procedure reduces glass breakage, improves quality assurance, and reduces installation costs.

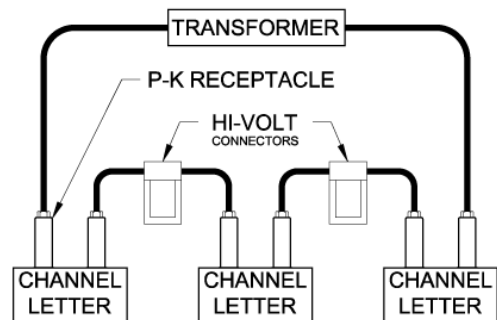

TYPICAL SIGN LETTER INSTALLATION



This product is Listed to applicable U.S. and Canadian standards and requirements by Underwriter's Laboratories, Inc.

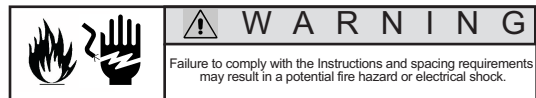

xs09049 07/14/101