

INSTALLATION INSTRUCTIONS

FRANCE *Tru-Power*™ Model LED-1260EPS LED Power Supply

- READ AND FOLLOW ALL SAFETY INSTRUCTIONS.
- Read and follow all instructions that are on the product or provided with the product.
- Installation work and electrical wiring must be done by qualified person(s) in accordance with all applicable codes and standards, including fire-rated construction.
- **WARNING: Risk of Electric Shock.** When used outdoors, install only on a circuit protected by a Class A GFCI.
- **WARNING: Risk of Fire.** Installation involves special wiring methods to run wiring through a building structure. Consult a qualified electrician.
- **WARNING: Risk of Electric Shock.** Mount the unit at a height greater than 1 foot from the ground surface.
- Turn power off at fuse or breaker panel before installation, inspection, service or removal.
- For use in Wet, Damp, or Dry locations.
- Power Supply must be properly grounded before operation.
- All wiring must be rated at 105°C or greater and installed per the National Electrical Code® (NEC) and applicable local codes.
- **SAVE THESE INSTRUCTIONS** – This manual contains important safety and operating instructions for power units.

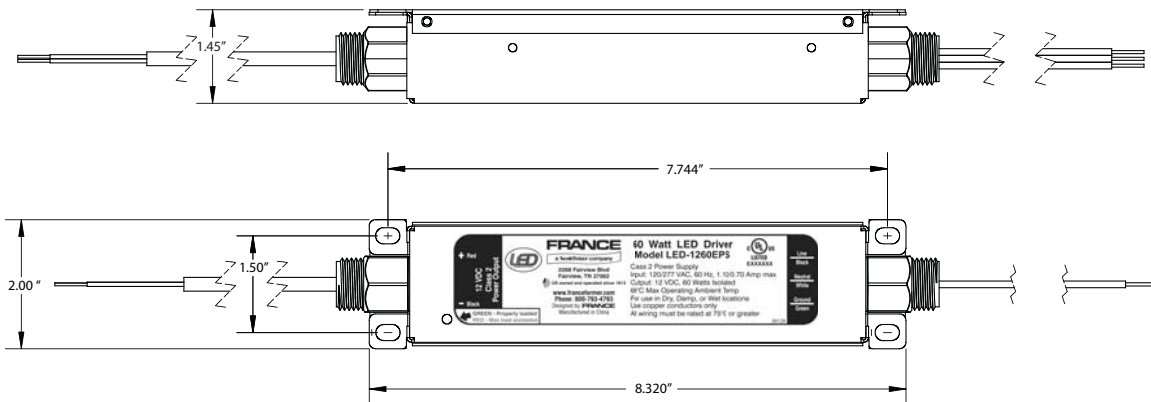

Power Supply Features

- The LED-1260EPS is a Class 2, 12VDC, 60 watt power supply for operating France or other approved LED Modules.
- Wet, damp, or dry location use: mountable indoors or outdoors in letters, raceways, transformer cans, or in weather-exposed locations (if installed per these instructions).
- Allowable operating ambient temperature adjacent to the power supply is -40°C to +60°C with proper mounting and air flow. No power derating is required for temperatures up to 60°C.
- Limits output current when overloaded - LED's will continue to operate, but will become progressively dimmer as the degree of overload increases, unless output is shorted. A visual status indicator lights GREEN when operating with rated load or less and RED if overloaded. The power supply will shut off and the indicator will blink RED if the output is very heavily overloaded or shorted.
- Low profile, fully potted construction provides maximum durability.
- 8" long input and output leads.
- UL Recognized.
- Complies with FCC Part 15.

Power Supply Specifications

At Input Voltage:	120 VAC	277 VAC
Input Frequency:	50/60 Hz	
Max Input Current:	1.10 Amp	0.70 Amp
Output Voltage:	12.0 VDC	
Max Output Current:	5.0 Amps	
Max Output Power:	60 Watts	



2268 Fairview Blvd., Fairview, TN 37062
(800) 753-2753 www.franceformer.com

INSTALLATION INSTRUCTIONS

FRANCE *Tru-Power*™ Model LED-1260EPS LED Power Supply

Step 1 Before you begin

Assure all power to the sign or mounting enclosure is turned off. Read these installation instructions thoroughly before beginning installation work. Electrical wiring of these power supplies shall be performed only by qualified service personnel in accordance with all applicable codes and standards, including fire-rated construction.

Step 2 Mounting and primary circuit wiring (see Fig, page 1)

The power supply ground wire (green) and any enclosure containing the power supply must be connected to branch circuit safety ground! Make sure to use the correct wire type for the application.

In the end product, power supply spacing to other heat producing components shall be located not less than 1 inch (25.4 mm) apart when arranged end-to-end, and not less than 4 inches (102 mm) apart when arranged otherwise.

In open air - dry location: Attach listed junction box to primary end of unit. Securely mount power supply/junction box via integrated mounting holes using a minimum of four No. 8 screws or bolts. If required, attach conduit to the junction box. If conduit is not used, attach listed strain relief to junction box. Route branch circuit wiring into box via the conduit or strain relief. Splice the line, neutral, and ground wires to the power supply leads as indicated on the product label. Attach cover to junction box.

Inside outdoor channel letter, raceway, or sign cabinet qualifying as an electrical enclosure per UL48 or in a remotely mounted electrical enclosure: Securely mount power supply via integrated mounting holes using a minimum of four No. 8 screws or bolts. Splice the line, neutral, and ground wires to the power supply input leads as indicated on the product label. When installed in an electrical equipment enclosure, that enclosure must have an internal volume not less than three times that of the power supply's volume (3 times volume = 75 in.3), and shall provide adequate ventilation to assure the maximum ambient air temperature near the power supply does not exceed 60°C (140°F). If adequate volume or ventilation is not supplied, the warranty is voided.

Inside outdoor channel letter, raceway, or sign cabinet not qualifying as an electrical enclosure per UL48: Attach junction box/attachment hardware listed for wet locations to primary end of unit. Securely mount power supply/junction box via integrated mounting holes using a minimum of four No. 8 screws or bolts. Using wet listed hardware attach conduit to the junction box. Route branch circuit wiring through the conduit into box. Splice the line, neutral, and ground wires to the power supply input leads as indicated on the product label. Attach cover to junction box. The power supply may also be installed in an enclosure within the sign in which case that enclosure must have an internal volume not less than three times that of the power supply volume (3 times volume = 75 in.3), and shall provide adequate ventilation to assure the maximum ambient air temperature near the power supply does not exceed 60°C (140°F). If adequate volume or ventilation is not supplied, the warranty is voided.

Exposed to weather - wet location: Attach junction box/attachment hardware listed for wet locations to primary end of unit. Securely mount power supply/junction box via integrated mounting holes using a minimum of four No. 8 screws or bolts. Using UL wet listed hardware attach conduit to the junction box. Route branch circuit wiring through the conduit into box. Splice the line, neutral, and ground wires to the power supply input leads as indicated on the product label. Attach cover to junction box.

Step 3 Secondary Circuit Wiring

Route the 12 VDC wiring from the LED load to the power supply per the requirements of NEC, UL48 and any local codes. Wiring between LED modules and power supply must be at least AWG 18 and kept as short as possible. If such wiring is exposed to rain, PLTC cable must be used. Connect +12VDC LED wires to the power supply RED output wire. Connect the -12 VDC LED wires to the power supply BLACK output wire as indicated on the product label. Use an NEC compliant splicing method listed for either wet or damp/dry, whichever is applicable. Use caution not to damage the wire insulation. If wiring in conduit is desired, secure a junction box (wet or dry/damp, whichever is applicable) to the secondary conduit coupling and splice wiring within junction box.

Step 4 Energize Circuit

Energize the primary circuit. If LED string lights and the status indicator is lit GREEN, the power supply is properly loaded and operating normally.

Troubleshooting

If, after applying power to the power supply's input leads, the status indicator lights RED, the power supply is overloaded. Remove one or more LED modules from the string until the status indicator lights GREEN. If the LED modules do not light and status indicator is blinking RED, a short exists in the LED string. Remove primary power and check all electrical connections for short circuit (pinched wires or defective LED module). Verify the LED modules' positive (+) and negative (-) leads are connected to the power supply's red and black leads respectively. If a portion or all of LED string does not light and the status indicator is lit GREEN, an open exists in the string. Repair any defective connections.

If the modules still fail to light, call Customer Service at France: 800-793-4793.

Note: A disconnect switch of the appropriate rating must be incorporated in the field within 29.5' (9 meters). The switch must be rated for the branch circuit voltage and twice the power supply input current.

WARRANTY POLICY

France, a Scott Fetzer Company, warrants to the original purchaser the following products to be free from defects in material and workmanship at the date of shipment. This warranty is conditional based upon proper installation, use and maintenance of the product. This warranty is not applicable to any product not installed and operated in accordance with France specifications and connection diagrams or which have been subjected to abnormal operating conditions.

NO OTHER WARRANTY, WHETHER EXPRESS OR IMPLIED, INCLUDING ANY WARRANTY OF MERCHANTABILITY OR FITNESS FOR A PARTICULAR PURPOSE, SHALL EXIST IN CONNECTION WITH THE SALE OR USE OF SUCH PRODUCTS. All claims under this warranty must be made in writing and delivered to the Company prior the expiration of the established warranty period from the date of manufacture.

Upon receipt of the claim, the Company shall inspect the part(s) claimed to be defective, and shall repair, or at its option, replace, free of charge, any part(s) determined to have been defective at the time of shipment from the factory. If circumstances are such as to preclude the remedying of warranty defects by repair or replacement, the Company shall, upon the return of the products, refund to buyer any part of the purchase price paid to the Company for the stated products. Inspection shall be performed at the Company's plant or at such other place as may be designated by the Company; and, freight for returning products for inspection shall be paid by the buyer.

The foregoing states the sole and exclusive remedy for any breach of warranty or for any other claim based on any defect in, or non-performance of, the products, whether sounding in contract, warranty or negligence. WITHOUT LIMITING THE GENERALITY OF THE FOREGOING, THE COMPANY SHALL UNDER NO CIRCUMSTANCES BE LIABLE FOR ANY INCIDENTAL OR CONSEQUENTIAL LOSS OR DAMAGE WHATSOEVER ARISING OUT OF, OR IN ANY WAY RELATING TO, ANY SUCH BREACH OF WARRANTY OR CLAIMED DEFECT IN, OR NON-PERFORMANCE OF, THE PRODUCTS.



2268 Fairview Blvd., Fairview, TN 37062
(800) 793-4793 www.franceformer.com